

A		36
B		64
C		36
D		05
E		01
F		20
G		34
H		03
I		32
J		08
K		100

L		Ø35 Dobradiça Super Curva	06
M		Calço Super Curva	06
N		3,5x16 Chata	06
P			24
Q			16
T			02
U		709mm	01

Utilizar a régua abaixo para medir os componentes.

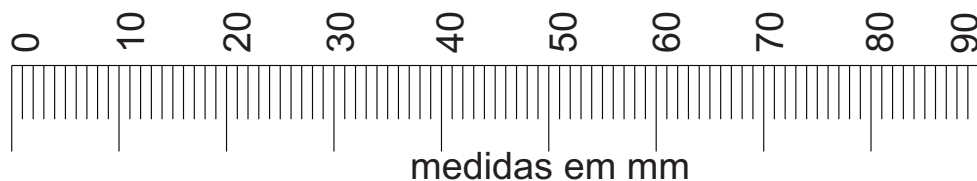

Nº Peça	Nome da Peça	Qtde
1	Tampo	01
2	Lateral Direita	01
3	Lateral Esquerda	01
4	Fundo	01
5	Prateleira Fixa Maior	01
6	Divisória Maior	01
7	Divisória Menor	01
8	Prateleira Fixa Menor	02
9	Travessa	01
10	Prateleira Móvel	04
11	Frente Gav. Superior Esq.	01
12	Frente Gav. Superior Dir.	01
13	Frente Gav. Inferior Esq.	01
14	Frente Gav. Inferior Dir.	01
15	Lateral Gaveta Direita	04
16	Lateral Gaveta Esquerda	04
17	Traseiro Gaveta	04
18	Fundo Gaveta	04
19	Traseiro Inferior	01
20	Porta	02
21	Aplique Porta	02
22	Traseiro Superior	02
23	Travessa Maior	02
24	Travessa Menor	02
25	Pé Torneado	04
26	Pé Central	01

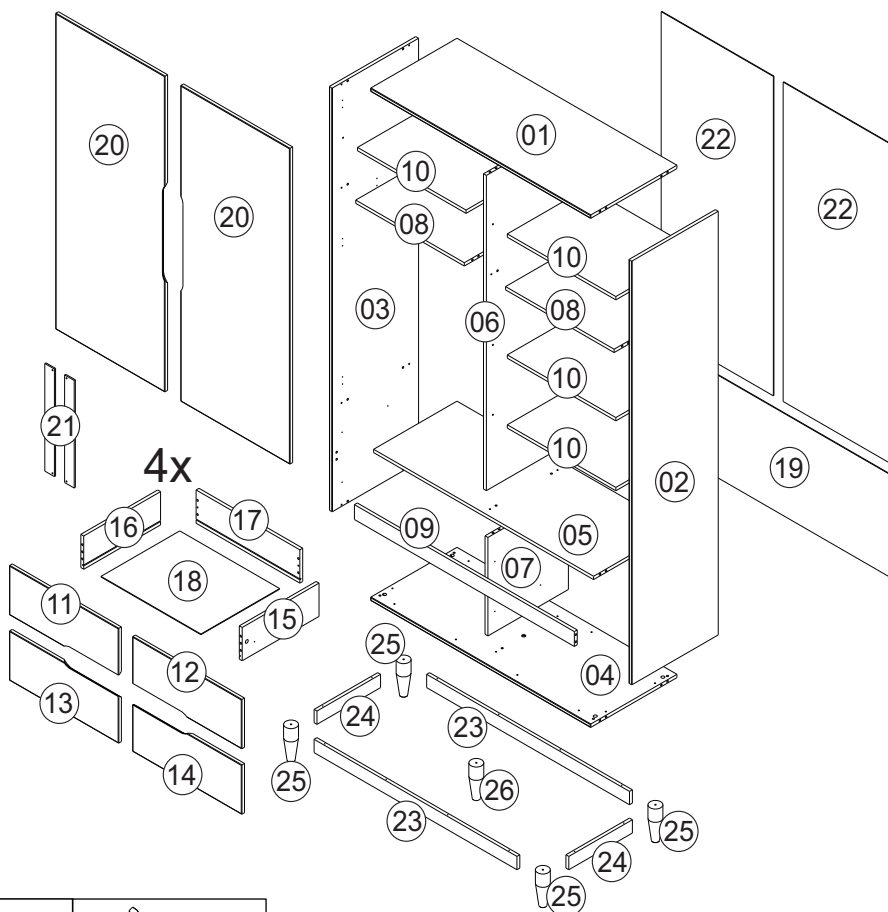

Ferramentas não fornecidas,
mas necessárias para a
montagem do produto.

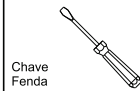

01

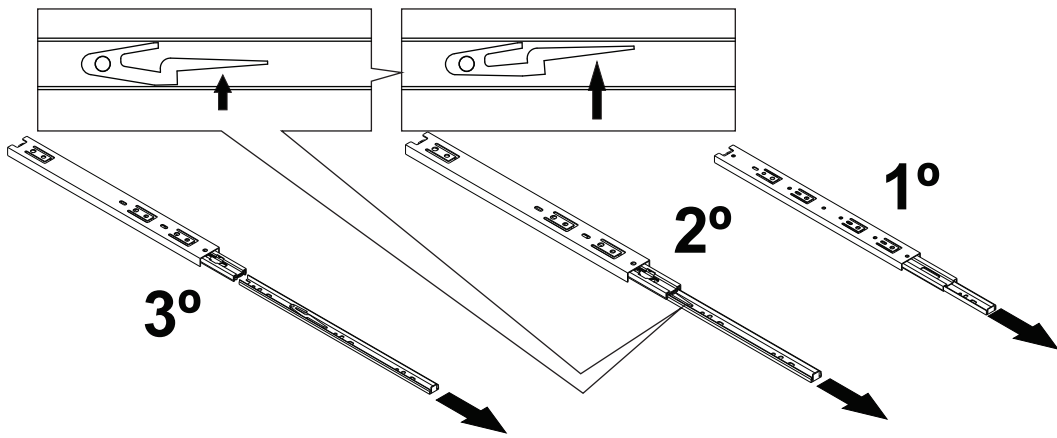

02

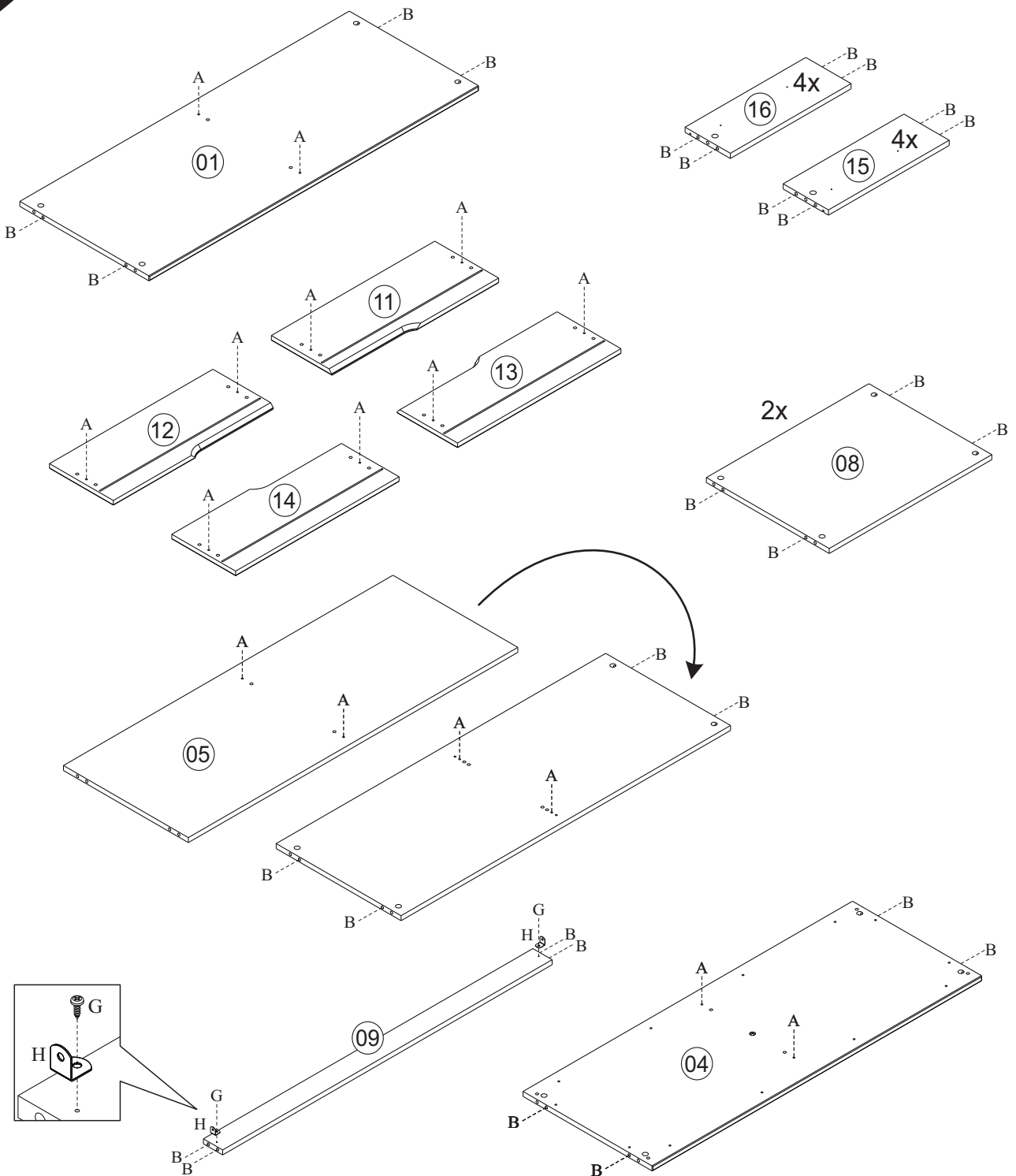

03

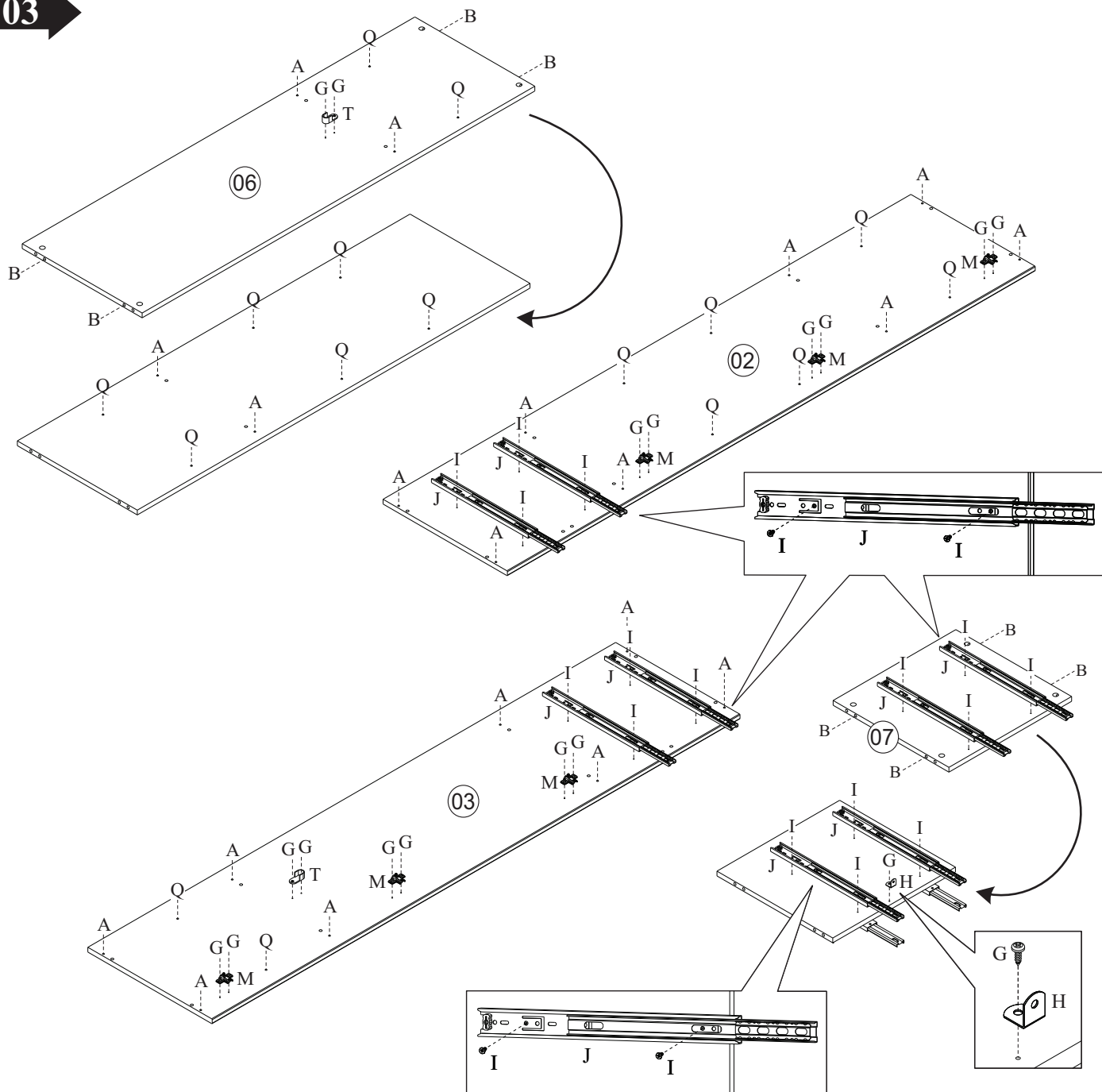

04

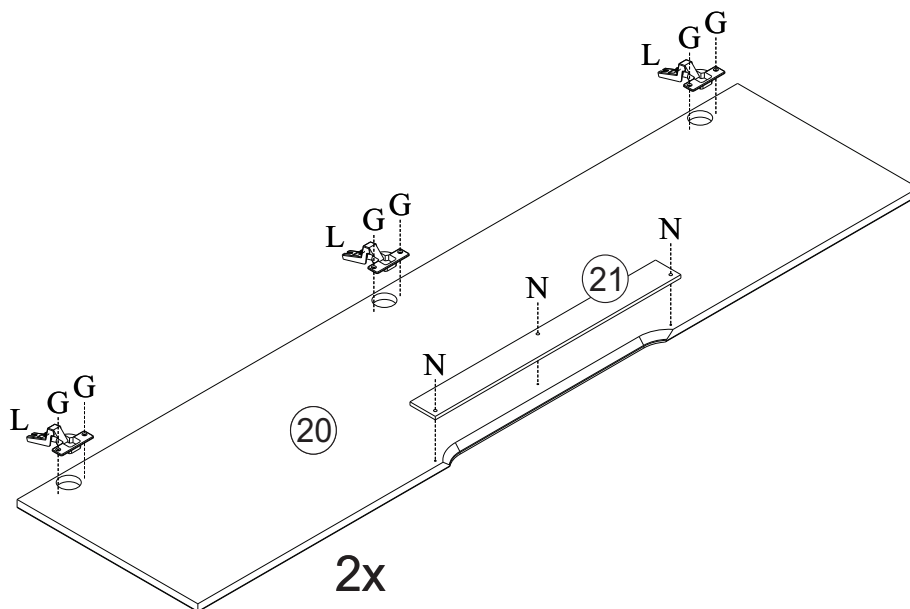

05 →

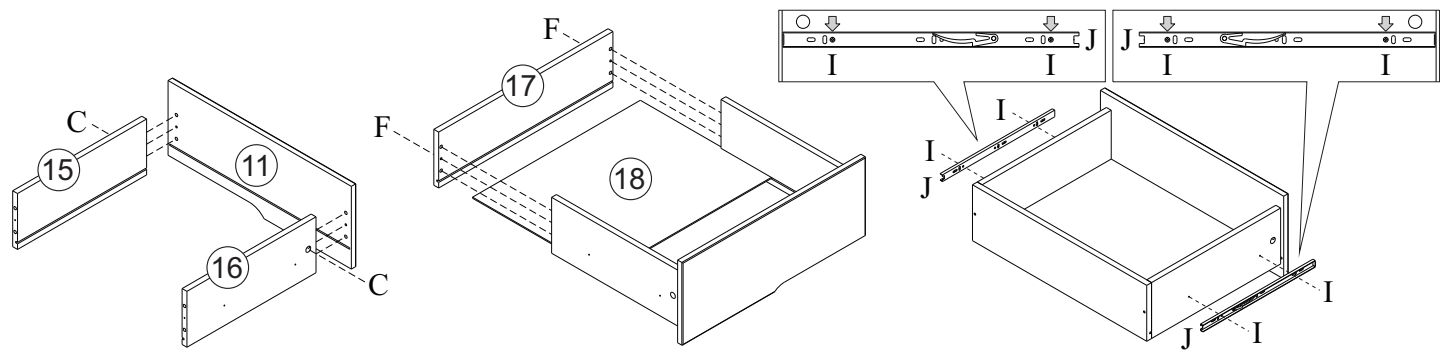

06 →

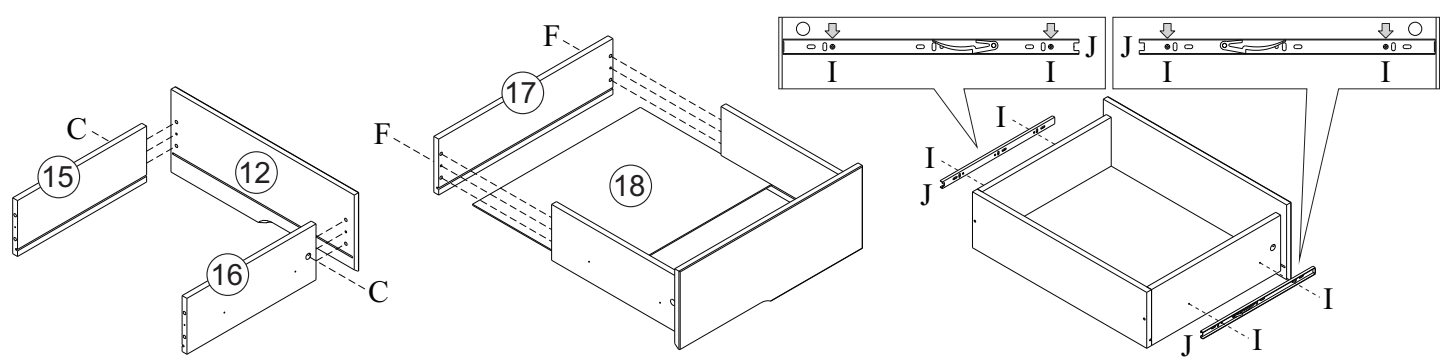

07 →

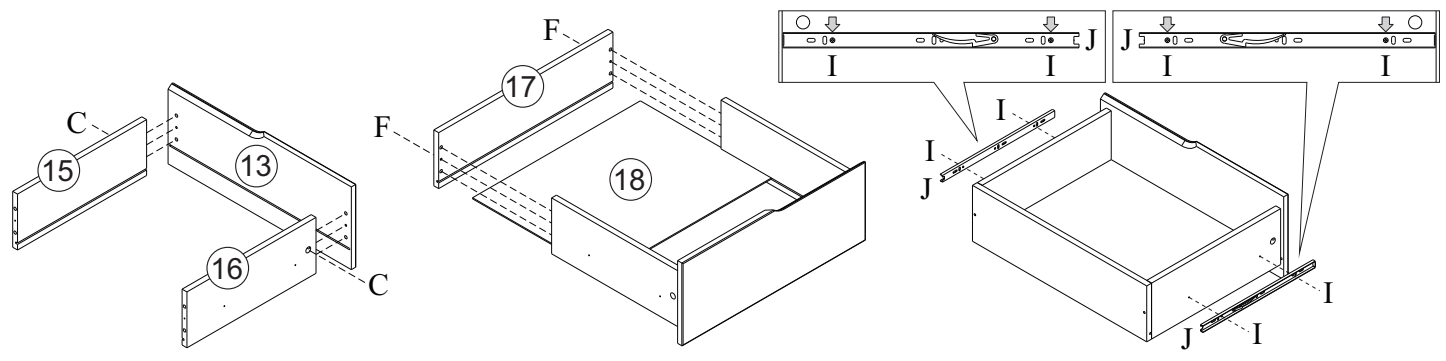

08 →

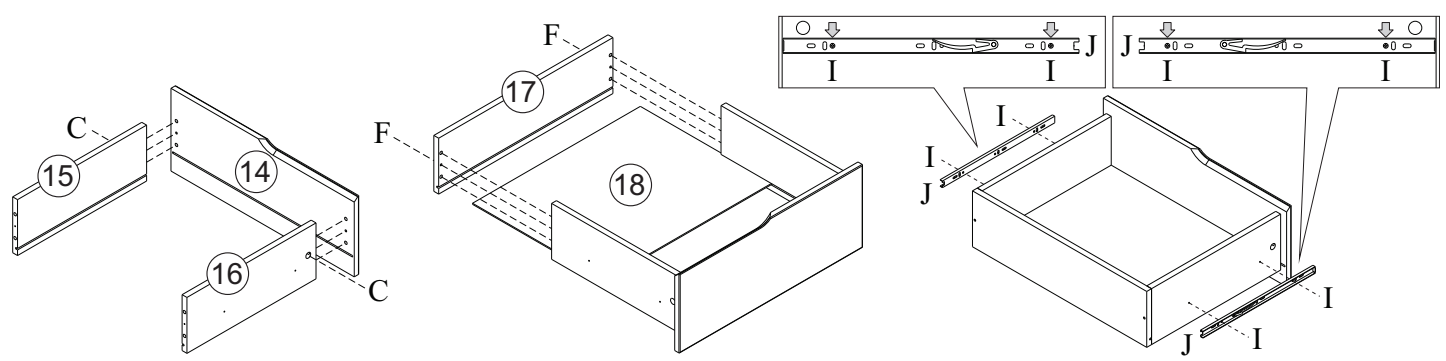

09

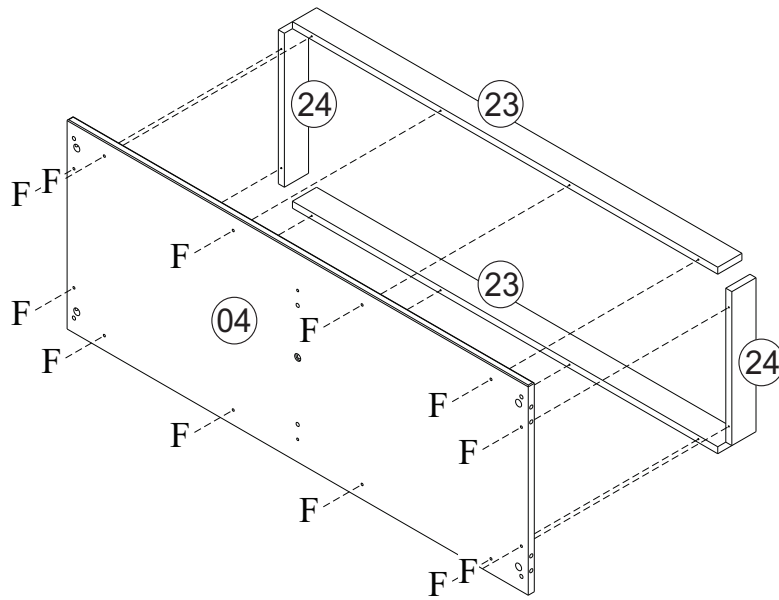

10

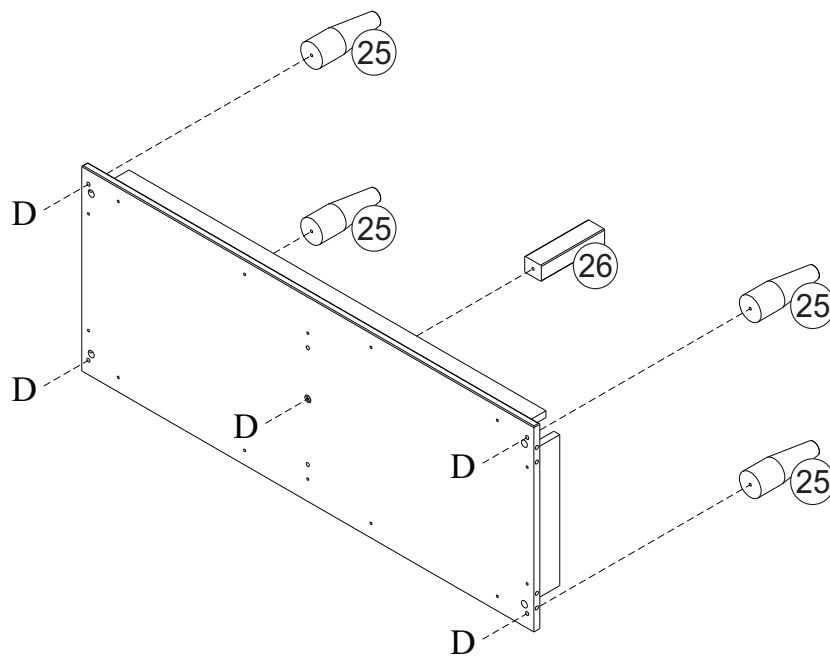

11

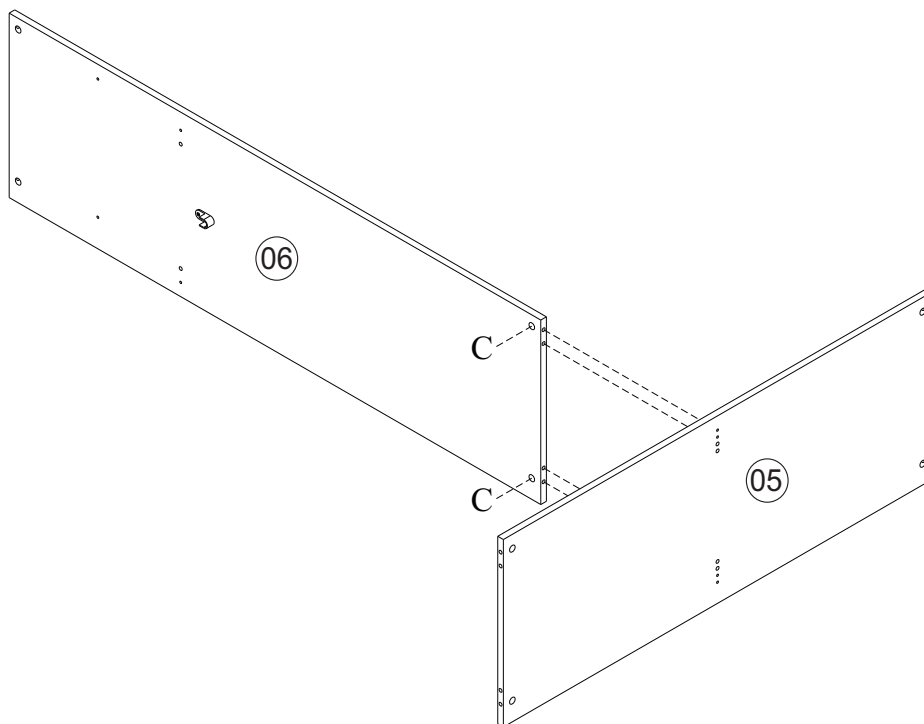

12

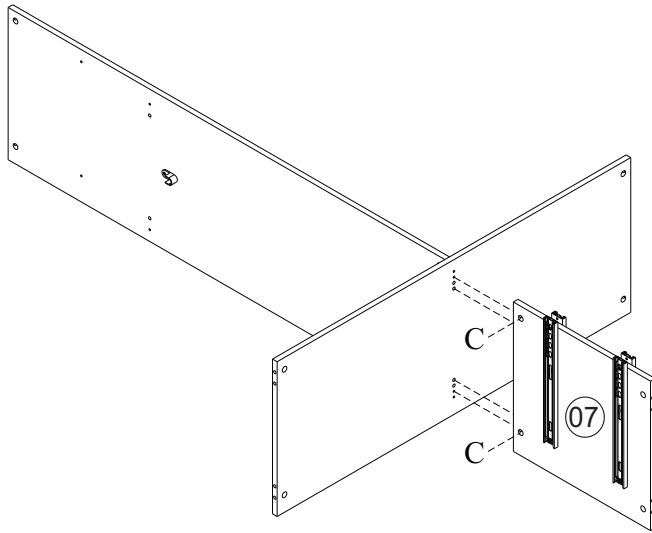

13

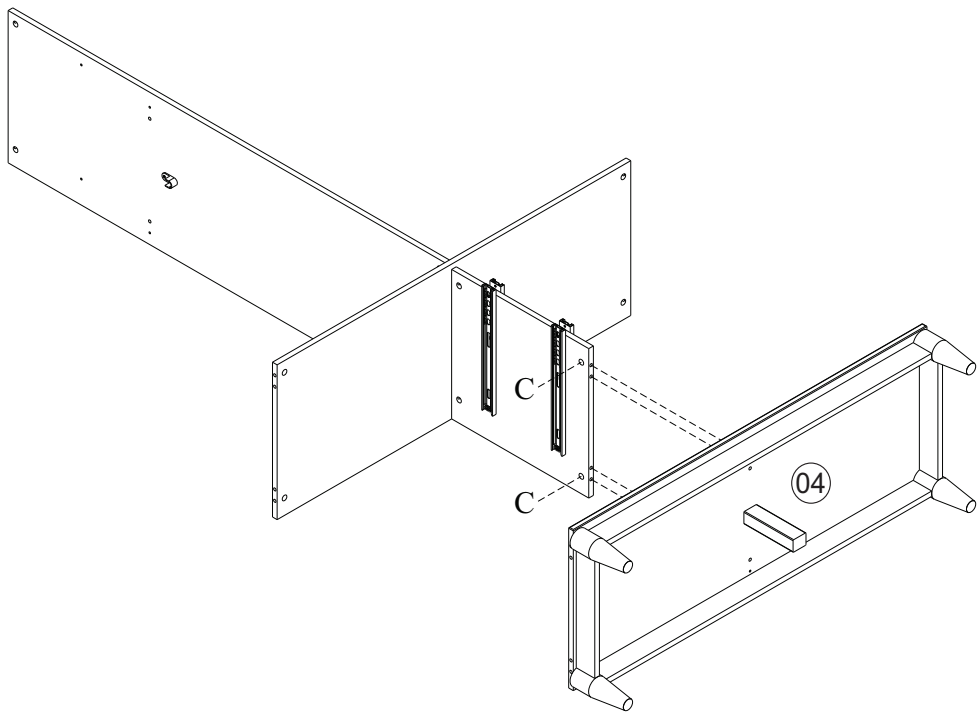

14

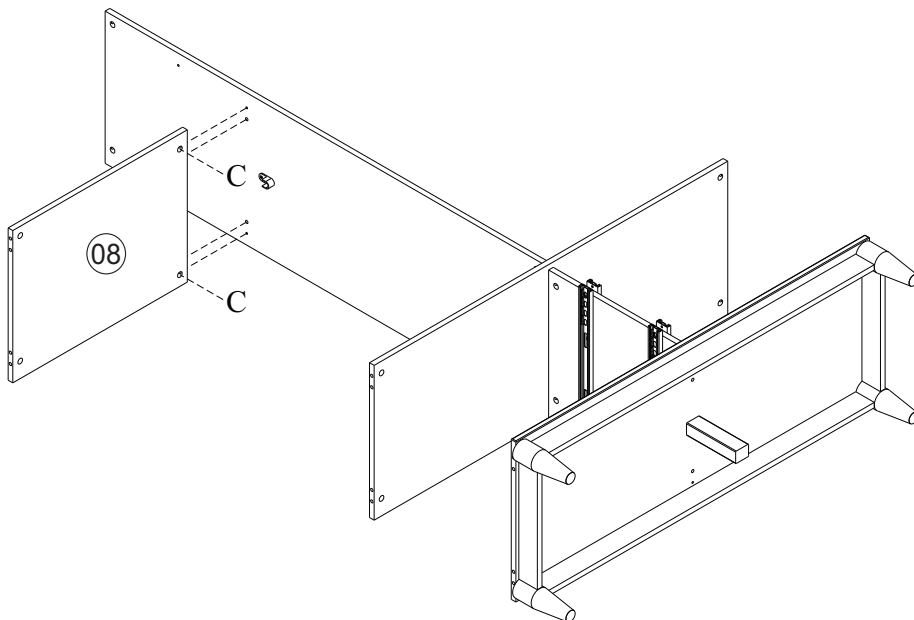

15

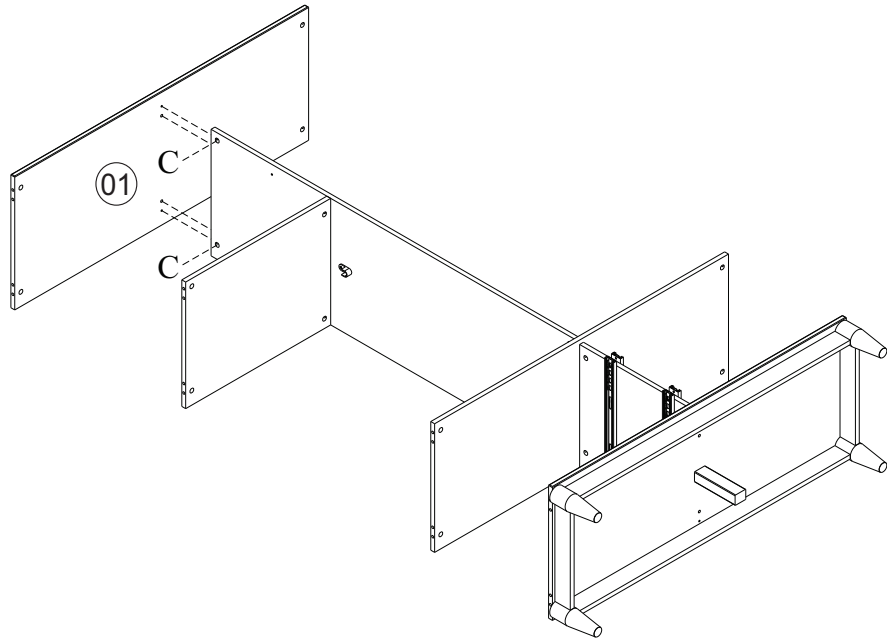

16

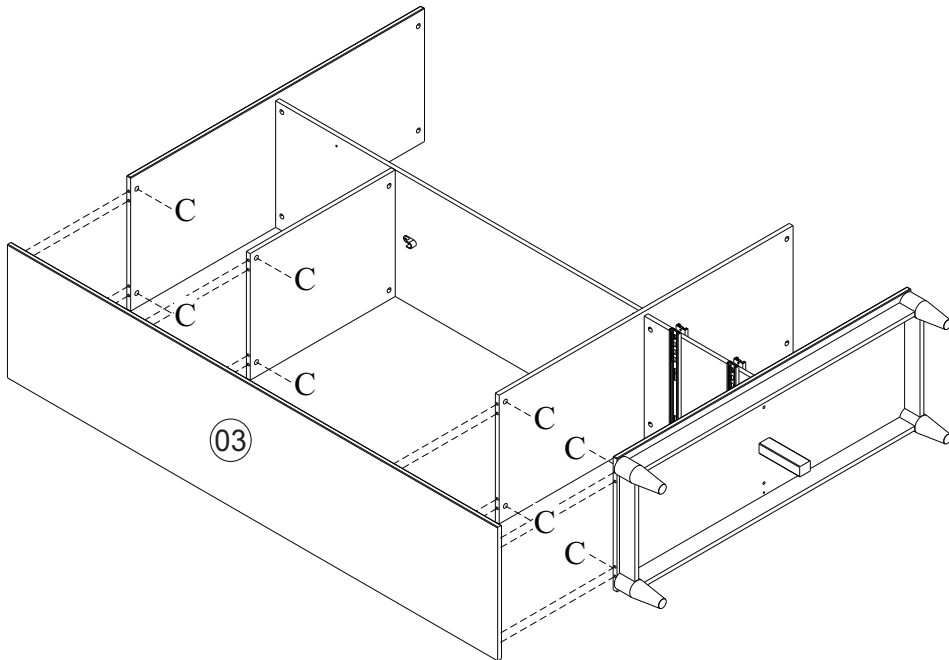

17

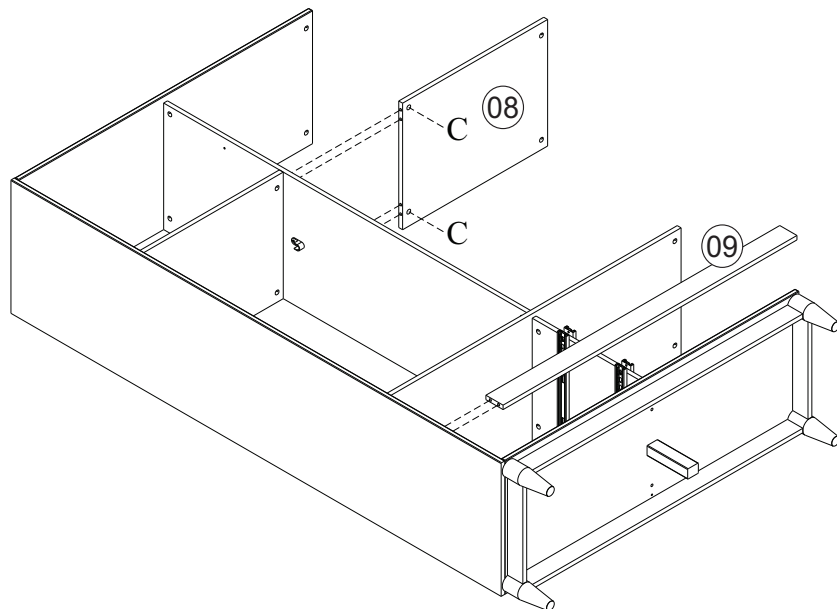

18

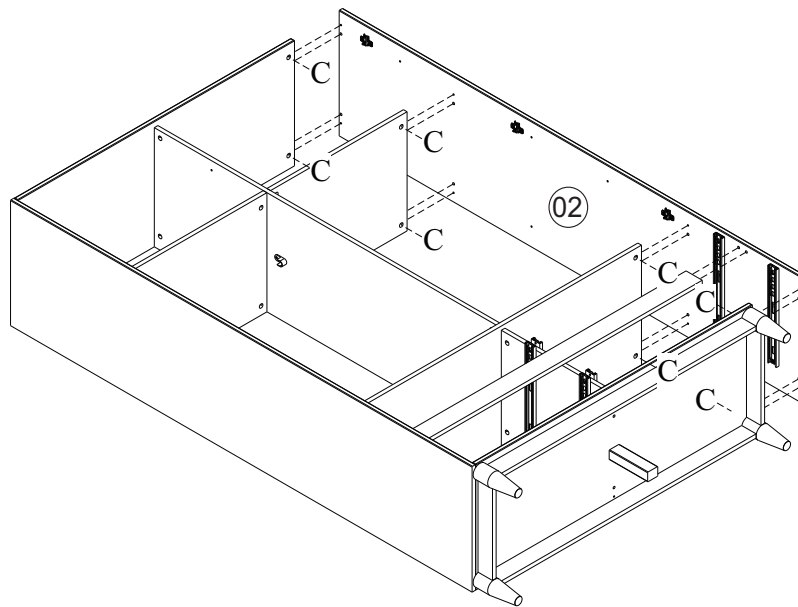

19

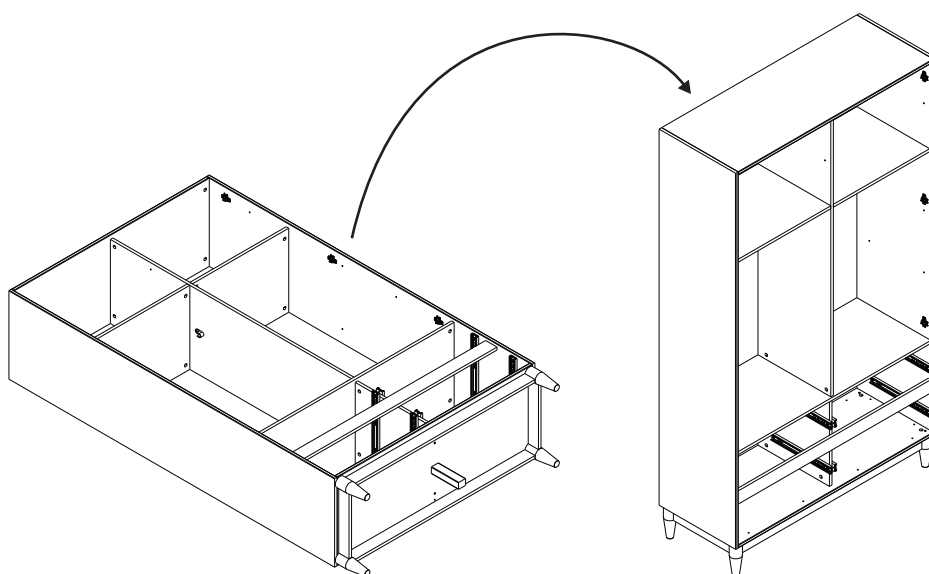

20

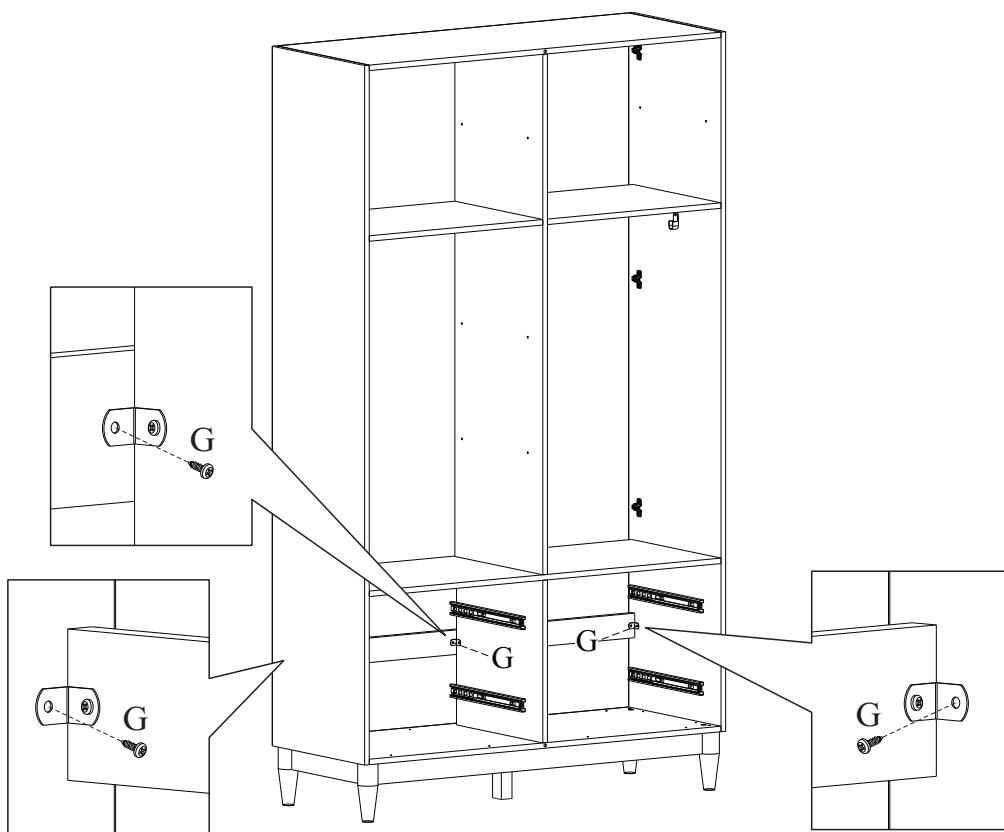

21

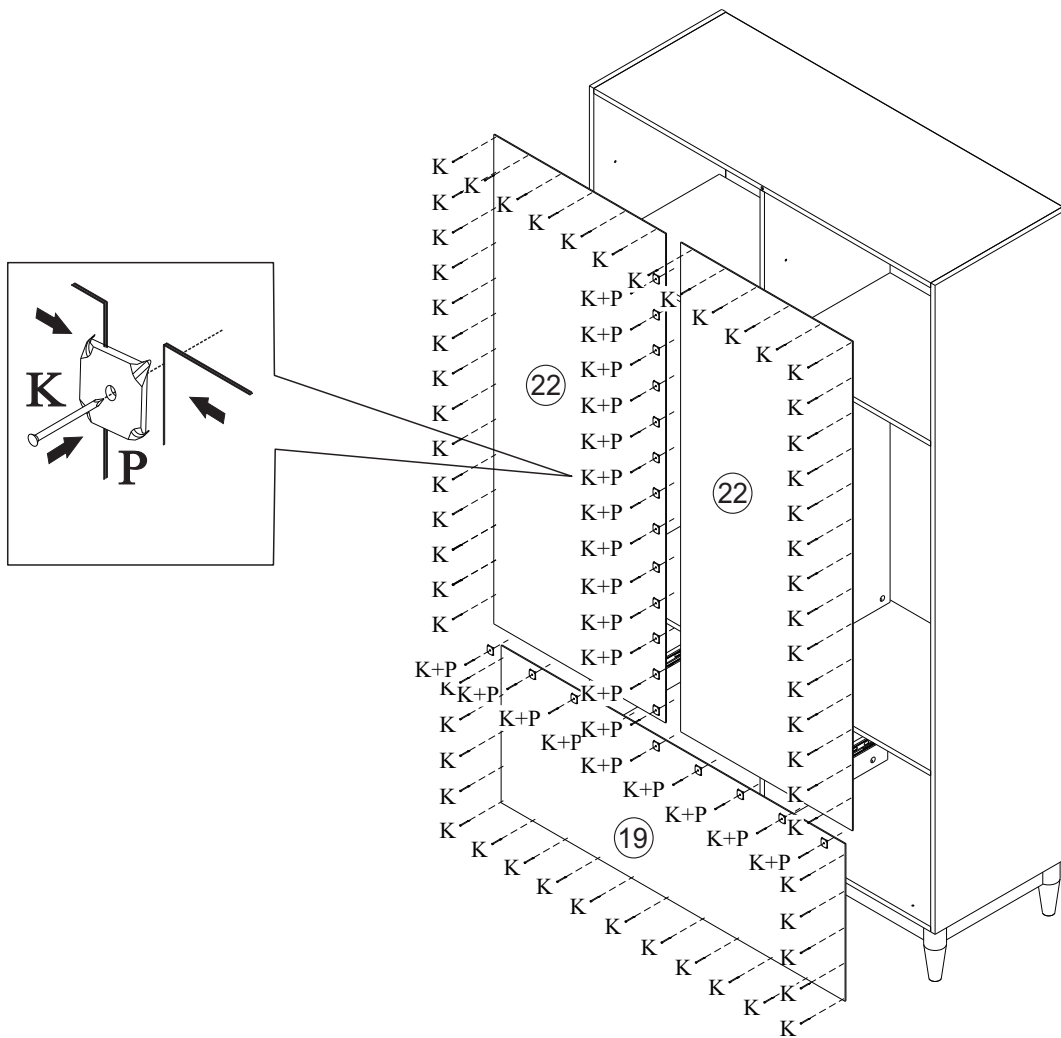

22

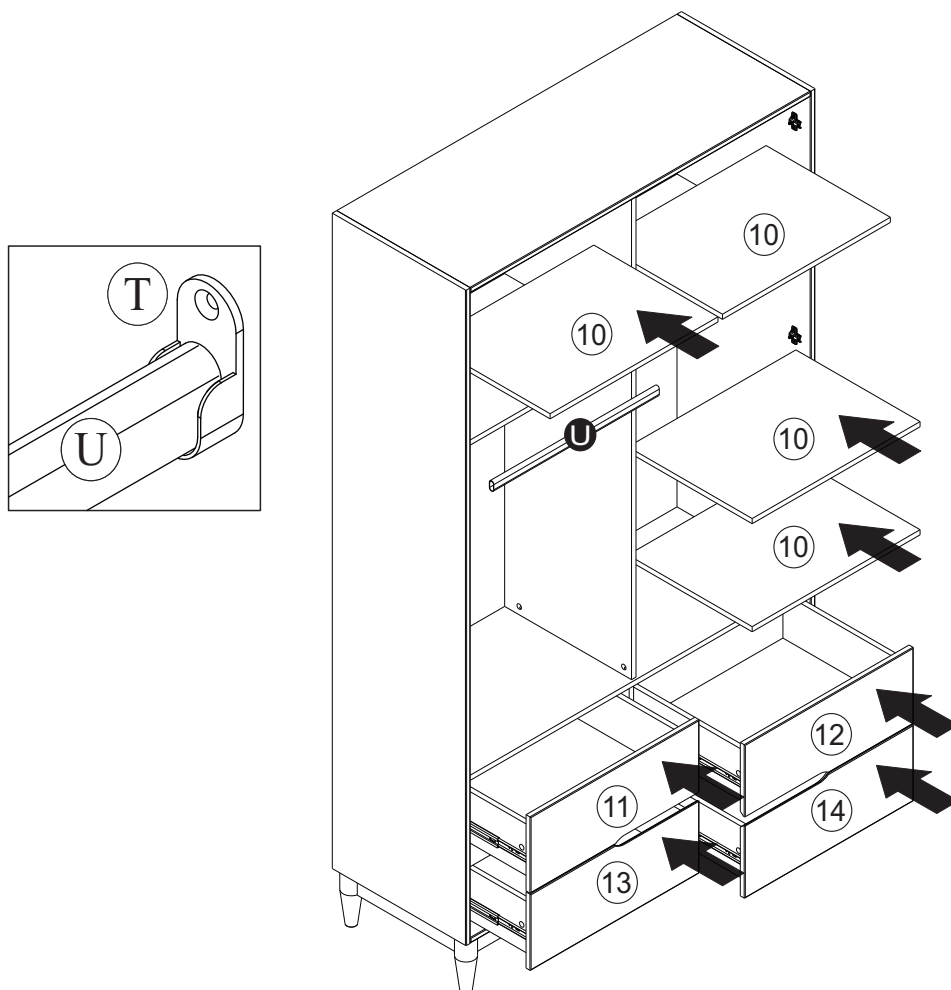

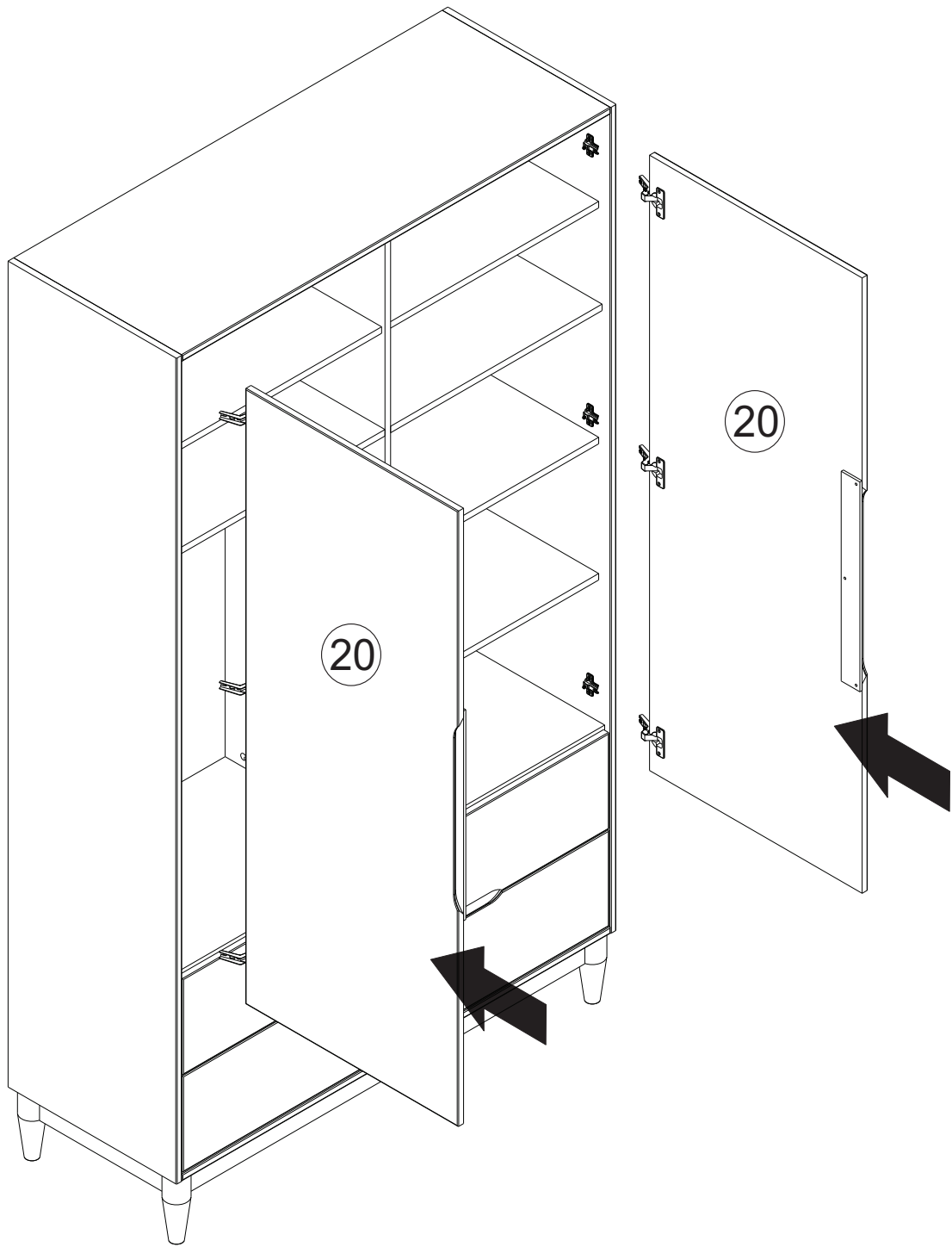

1°

2°

